



## PM240-series 216 to 240 W

### INPUT / OUTPUT

- Optimized input voltage ranges
- Input ranges from 18 to 300 Vd.c.
- Single outputs from 24 to 110 Vd.c.
- Reverse input voltage protection
- 2.5 kVa.c. isolation input/output, input/case, output/case

### FEATURES

- Overvoltage protection OVP
- Extra output with series diode
- Over/Under voltage alarm relay

INPUT		
Nominal inputs	Input range	Code
24 Vd.c.	18-32 V	24
48 Vd.c.	38-60 V	48
110, 127 Vd.c.	88-150 V	110
220, 250 Vd.c.	175-300 V	220

### OPERATION

- Operating temperature range -25 to +55 °C and +70 ° with derating.
- High efficiency.
- Fully encapsulated, meets IP20 as standard.
- Convection cooled.
- Output voltage adjustable on frontpanel.

### EMC

- EN IEC 61000-6-3, Emission.
- EN IEC 61000-6-2, Immunity.
- EN IEC 61000-4-4, 4 kV.
- EN IEC 61000-4-5 level 2 & 3.

OUTPUT		
Voltage	Current	Power
24 V	9-10 A	216-240 W
36 V	6.7 A	240 W
48 V	4.5-5 A	216-240 W
60 V	3.6-4 A	216-240 W
110 V	1.97 - 2.2 A	216-240 W

## OUTPUT RATING & TYPE CODE

OUTPUT			INPUT			
Voltage	Current	Power	18 - 32 V	38 - 60 V	88 - 150 V	175 - 300 V
24 V	9.00 A	216 W	PM240 24/24			
24 V	10.0 A	240 W		PM240 48/24	PM240 110/24	PM240 220/24
36 V	6.70 A	240 W		PM240 48/36		
48 V	4.50 A	216 W	PM240 24/48			
48 V	5.00 A	240 W		PM240 48/48	PM240 110/48	PM240 220/48
60 V	3.60 A	216 W	PM240 24/60			
60 V	4.00 A	240 W		PM240 48/60	PM240 110/60	PM240 220/60
110 V	1.97 A	216 W	PM240 24/110			
110 V	2.20 A	240 W		PM240 48/110	PM240 110/110	PM240 220/110

How to read our product code: Example PM240 110/24

PM240 = Family code

110 = input voltage code 110

24 = Output voltage 24 V

## FEATURES

### Overvoltage protection OVP

The output voltage is limited to 15 % over nominal output voltage by an extra regulation circuit.

### Extra output with series diode

Use the series diode output when the output is connected in parallel with other power supplies to achieve redundancy.

### Over / Under voltage alarm

The built in relay changes to alarm state if the converter output voltage is not within 90 to 115 % of nominal output. The user can select NO or NC relay function. The relay rating is 30 V 0.5 A (d.c. or a.c.)

## OPTIONAL FEATURES

### Inrush current limit with NTC

Reduces the inrush current during start up. The input voltage range will be affected. Only available on 110 & 220 input code.

### Conformally coating

For environment with high non condensing humidity max 98 % RH.

### +70 °C operating temperature

Contact factory for derating as it depends on model. The alarm can not be used at +70 °C.

### Mounting brackets L214-1

See figure 3.

### 19" Rack mounting set PL88-2

To mount two PM240 together to form a full 19" rack unit, see figure 2.

### 19" Rack mounting bracket PL88-3

To mount one PM240 to form a full 19" rack unit, see figure 2.

### EN IEC 61000-4-5 level 4

External varistor + surge arrestor mounted from pole to ground. With this filter the input meets level 4 of EN IEC 61000-4-5 (+/-2 kV line to line, 4 kV line to ground)

### DIN-rail clips

Clips to mount PM240 on a 35 mm DIN-rail. (Used with PL88-1 & L-214 see figure 3)

### Train input

Input voltage range according to train standard EN 50155 and IEC 60571.

## GENERAL DATA / INPUT DATA

LABEL	VALUE
Design topology	Push-Pull
Switching frequency	30 kHz
Emission / Immunity	See page 4
Safety EN IEC 60950	Class I
Max. accepted input ripple <sup>1</sup> 50-400 Hz	2 % of nominal voltage
Input power at no load Uout <55 V	Max. 9 W
Input power at no load Uout >55 V	Max. 20 W
Inrush current limit	No
<b>Reverse input voltage protection</b>	
24, 48 input code	Parallel diode
110, 220 input code	Series diode
Dimensions (D x W x H)	160 x 214 x 88 mm
Weight	2.5 kg

1. Higher ripple affects the input, contact factory

2. The output ripple might increase to 0.5% RMS of Vout, when EN IEC 61000-4-3, 10 V/m test is applied.
3. Lowest efficiency measured within the whole input voltage range at 100% load.
4. Contact factory for derating as depends on model. The alarm relay can not be used at +70 °C

## OUTPUT DATA

LABEL	VALUE
Source regulation	0.1%
Load regulation (0 to 100% load)	0.3%
Transient recovery time for 10 to 90 % load step to within 3 % of nominal output voltage.	<3 ms
Output ripple (60 kHz) <sup>2</sup>	30 mV p-p
Input ripple attenuation to output (50 to 400 Hz)	150:1
Emission / Immunity	See page 4
Temperature coefficient	0.02%/°C
Min output adjustment range adjustable with a 15 turn potentiometer	95 - 110%
Current limit, rectangular	105%
Remote sense	No
Soft start	Yes
Start-up time	1 s
Hold-up time, contact factory	2 - 25 ms
Efficiency <sup>3</sup>	88 - 91%
Operating temperature range at 100% load. (Convection cooling) with derating <sup>4</sup>	-25 to +55 °C +70 °C
Storage temperature range	-40 to +85 °C

## MECHANICAL DRAWING

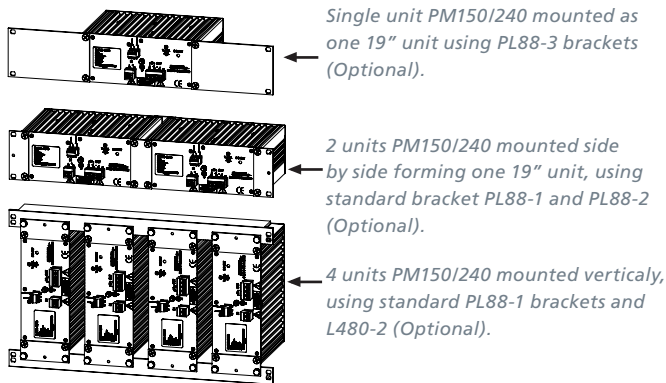
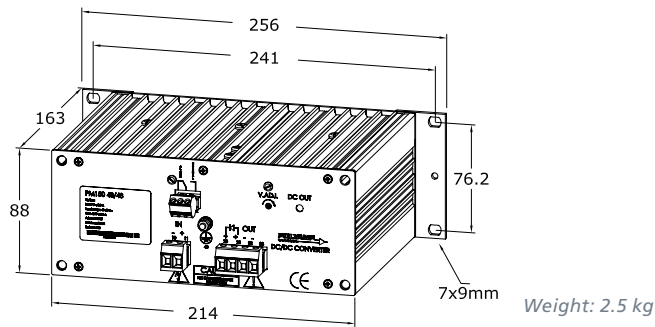

Figure 2. 19"-rack mounting

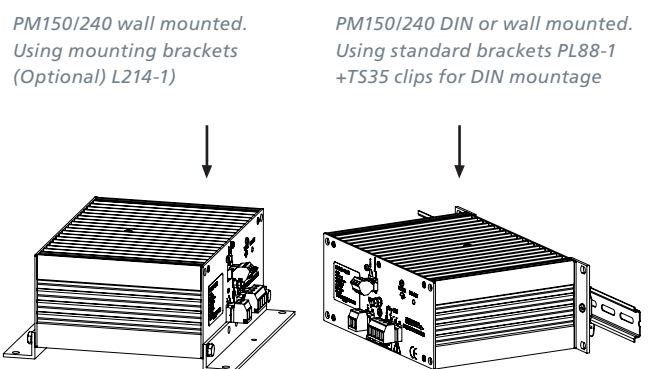

Figure 3. Wall and chassis mounting

## CE MARK

PM240 meets the requirements defined by CE mark as apparatus.

PM240 meets requirements of EMC directive and low voltage directive (LVD) and RoHS II directive.

The PM150 family is in respect to EMC, a stand alone unit that can also be installed in any other environment by a professional installer.

Please note that product standards can demand different levels or other basic standard tests. We test according to levels below. For higher levels or other tests, contact factory

## SAFETY STANDARD EN/IEC 60950

ISOLATION TESTABLE LEVELS	TEST VOLTAGE
Input / Output	2.5 kVa.c. / 4 kVd.c.
Input / Case	2.5 kVa.c. / 4 kVd.c.
Output / Case all outputs	2.5 kVa.c. / 4 kVd.c.
Input / Alarm	2.5 kVa.c. / 4 kVd.c.
Output / Alarm	2.5 kVa.c. / 4 kVd.c.
Case / Alarm	2.5 kVa.c. / 4 kVd.c.

## EMC

EMC STANDARDS	EMC PERFORMANCE		REMARKS
<b>Emission standards</b>	<b>EN IEC 61000-6-3</b>		<b>Commercial and light-industrial environments</b>
	<b>Input</b>	<b>Output</b>	
EN 55016 CISPR 16 (0.15-30 MHz)	OK	OK	opt.EN 55022 level B
EN 55016 CISPR 16 (30-1000 MHz)	OK		Enclosure test
<b>Immunity standards</b>	<b>EN IEC 61000-6-2</b>		<b>Industrial environments</b>
EN IEC 61000-4-2	8 kV / 8 kV		Contact / air, Enclosure test
EN IEC 61000-4-3	10 V/m AM-Modulated		Output ripple can increase to 0.5% of Vout Enclosure test
EN IEC 61000-4-4	± 4 kV	± 4 kV	
EN IEC 61000-4-5, Input code 24, 48	± 0.5 kV / ± 1 kV	± 0.5 kV / ± 1 kV	Line-line 2 Ω / Line-case 12 Ω
EN IEC 61000-4-5, Input code 110, 220	± 1 kV / ± 2 kV <sup>1</sup>	± 0.5 kV / ± 1 kV	Line-line 2 Ω / Line-case 12 Ω
EN 50121-3-2 IEC 62236-3-2	± 1 kV / ± 2 kV	± 1 kV / ± 2 kV	Line-line 42 Ω / Line-case 42 Ω
EN IEC 61000-4-6	10 V <sub>RMS</sub>	10 V <sub>RMS</sub>	AM-Modulated
EN IEC 61000-4-8	Not sensitive		Enclosure test
EN IEC 61000-4-10	Not sensitive		Enclosure test

1. Higher level 2 kV / 4 kV with external filters, contact factory.

We use the EMC product standard "Low voltage power supplies DC output" EN 61204-3 as base for measurement principles. The Immunity EMC levels are elevated in order to comply to EN 50121-3-2 (IEC 62236-3-2) Railway application: Rolling stock – Apparatus, and EN 50121-4 (IEC 62236-4) Railway application: Signaling and telecommunication apparatus. Also to meet relevant parts of IEC 61000-6-5 Generic Standards – Immunity for power stations and substation environments.



- A secure part of your system

### HEAD OFFICE

Polyamp AB  
Box 925  
SE-191 29 Sollentuna  
Sweden  
Phone: +46 8 594 693 00  
Telefax: +46 8 594 693 05

### SALES OFFICE

Polyamp AB  
Box 229  
SE-597 25 Åtvidaberg  
Sweden  
Phone: +46 120 854 10  
Telefax: +46 120 854 05

### SALES OFFICE

Switch Craft S.A  
Ruel bel Air 63  
CH-2300 La Chaux-de-fonds  
Switzerland  
Phone: +41 32 96 78800  
Telefax: +41 32 96 78809

Email: [info@polyamp.se](mailto:info@polyamp.se)  
[www.polyamp.com](http://www.polyamp.com)